

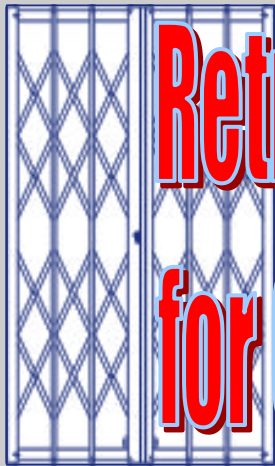

CCX3 System



Retractable High-Security Grilles for Commercial Purposes



Seriously Strong Security





CCX3 System

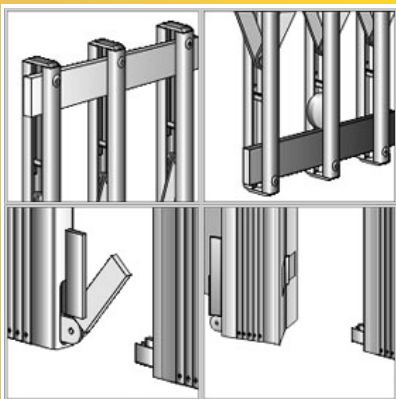

RETRACTABLE HIGH-SECURITY GRILLES

The ultimate grille for strength and flexibility of installation, the CCX3 is a retractable high-security grille particularly suitable for security of windows and doors in commercial premises and high-risk environments.

- **Patented Crosslinx® Rivetless System** for added strength provides a much stronger and more attractive alternative to rivets.
- **Made to measure** to meet individual customer requirements.
- **Discreetly stacks back** to a fraction of the overall size.
- **Ease of access** – a low profile bottom track allows ease of access to wheelchairs and pushchairs.
- **Secure and easy-to-close** patented multi-point slam shut lock ensures outstanding protection and ease of use. A number of grilles can also be operated from a single key.
- **Anti-jemmy security strip** protecting the lock from attack with a crowbar or other lever.
- **Strong durable finish** in high-quality powder-coating
- **Wide choice of colours** to blend in with any colour scheme.
- **Exceptionally low maintenance** with a zinc plated anti-rust finish and no electrics to go wrong. Costly service and maintenance contracts are not necessary.
- **12-month guarantee** – in the unlikely event of a quality problem.
- **Planning permission** is not usually required.

PRODUCT INFORMATION

- *Traditional diamond shaped lattice*
- *Bottom rolling design with the top and bottom tracks integrated within the grille for extra strength*
- *No top or bottom fixings are required making the grille particularly useful when fitting to uneven openings*
- *Available as a single grille (locking to one side) or double grille (central lockpost)*
- *For maximum accessibility in doorways – “lift-up” and “lift-out” bottom track options are available as well as a swivel return to hinge back the stack of the grille when open.*

CERTIFICATION

The CCX3 is a new grille that has been submitted for third party testing and certification.

Seriously Strong Security

CENTURION

WESTHILL BUSINESS CENTRE, ARNHALL BUSINESS PARK, WESTHILL, ABERDEEN AB32 6UF

Tel: 01224 744440 • Fax: 01224 744819

email: info@centurionsecurity.co.uk

www.centurionsecurity.co.uk

Security • Confidence • Peace of Mind